

AEHD 500



Regenerative compressed air dryers use desiccant to adsorb water vapor from the compressed airstream. In the twin tower design one tower dries the air from the compressor while the desiccant in the other tower is being regenerated to provide continuous operation. These dryers are typically referred to as “heatless” or “heated”. Heatless dryers do not use any source of heat for regeneration other than the heat given off during the drying phase. This is known as the “Heat of Adsorption”. Heated dryers, on the other hand, utilize an external heat source for regeneration and require little or no process air.

The **Aircel AEHD Series Dryers (150 - 3,000 scfm)** utilize process air for regeneration of the desiccant bed similar to the heatless designs. However, this expanded process air is heated prior to entering the off-line bed, significantly reducing the required consumption and the cost of operation. Additionally process air is consumed during depressurization of the offline desiccant tower. In total these functions amount to an average process air use of 7% of the rated capacity of the dryer.

AEHD Series Features

- Removable, stainless steel desiccant bed support screens.
- Tower pressure gauges.
- ASME code desiccant towers (6” vessels and larger).
- High temperature outlet check valves.
- Fail-safe design.
- 1-1/2” thick fiberglass insulation.
- Highly reliable programmable logic control (PLC).
- Energy saving venturi option available on request.

AEHD SERIES How it Works

Filtering and drying incoming air. Hot, saturated compressed air is filtered as it passes through our 0.01 micron high-efficiency coalescing prefilter (F1, recommended option) before entering the dryer. Compressed air continues through the inlet valve (V1), is dried in the desiccant tower (T1), and exits through an outlet valve (V5) and final particulate filter (F2, recommended option), while the other desiccant tower (T2) is being regenerated.

Desiccant regenerated in T2. A portion of the dried air is diverted through purge valve (P3) at near atmospheric pressure and heated by the electric heater (or optional steam heater) to 400°F before passing through regeneration valve (V4) and into the regeneration tower (T2).

The heated air removes moisture vapor from the desiccant surface.

Dryer operation is performed automatically by a programmable logic controller (PLC). The standard drying and regeneration time cycle is 8 hours. While one tower is drying incoming compressed air for 4 hours, the other tower is regenerating for 3 hours (heating time), then cooling for 50 minutes, and finally repressurizing to the line pressure for 10 minutes before switching over to the other tower. Switching from one tower to the other is performed only when both desiccant towers are at line pressure to prevent line surge and to minimize desiccant abrasion.

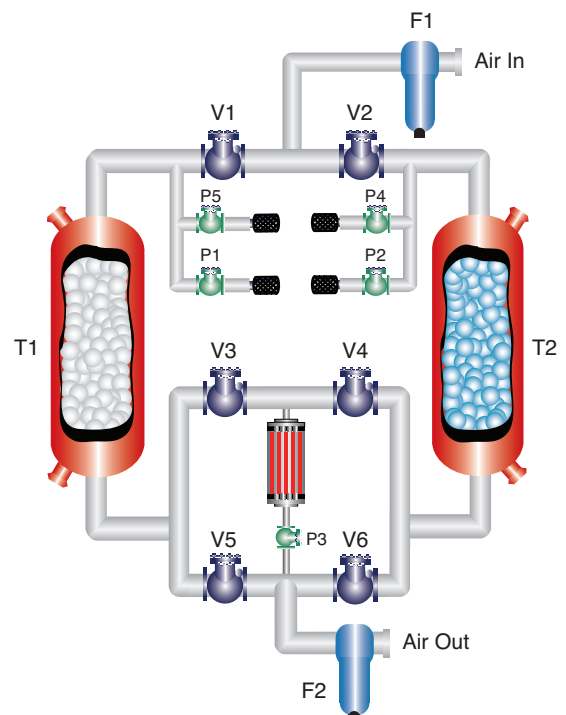

AEHD SERIES TECHNICAL SPECIFICATIONS



AEHD SERIES Model Comparison

Model	Capacity ¹ (scfm)	Connection (inches FNPT/ANSI)	Heater kW	Full Load Amps	Voltage (Standard)	Dimensions (inches)			Pressure max. (psig)	Weight (lbs)	Desiccant Both Vessels (lbs)
						Height	Width	Depth			
AEHD-150	150	1	2.5	3.2	460V/60 Hz/3Ph	75	45	30	150	810	200
AEHD-250	250	1-1/2	4.5	6.2	460V/60 Hz/3Ph	75	50	35	150	1200	400
AEHD-350	350	2	6	8.1	460V/60 Hz/3Ph	75	54	35	150	1600	500
AEHD-500	500	2	9	11.8	460V/60 Hz/3Ph	83	60	39	150	2000	700
AEHD-750	750	3 FLG	12	15.6	460V/60 Hz/3Ph	89	75	44	150	2600	960
AEHD-1000	1000	3 FLG	15	19.3	460V/60 Hz/3Ph	98	88	54	150	3500	1400
AEHD-1200	1200	3 FLG	20	25.6	460V/60 Hz/3Ph	109	96	60	150	3900	1800
AEHD-1500	1500	4 FLG	24	30.6	460V/60 Hz/3Ph	109	102	69	150	4500	2100
AEHD-2000	2000	4 FLG	30	38.2	460V/60 Hz/3Ph	115	120	69	150	5800	2800
AEHD-2500	2500	4 FLG	36	45.7	460V/60 Hz/3Ph	115	130	73	150	6600	3600
AEHD-3000	3000	6 FLG	45	57.00	460V/60 Hz/3Ph	120	140	77	150	7500	4200

¹ Capacity based on -40°F dpd, 100 psig operating pressure, 100°F inlet temperature and 100°F ambient temperature according to CAGI ADF 200. Ambient air temperature: 38-125°F; inlet air temperature: 40-110°F; operating pressure: 60-150 psig. Standard power supply: 460V/60 Hz/3Ph. Due to a continuous program of product improvement, specification and dimensions are subject to change without notice.

AEHD SERIES Capacity Correction Factors

To Size the Dryer Capacity for Actual Conditions

Adjusted Capacity = scfm x C1 x C2

To calculate the capacity of a given dryer based on non-standard operating conditions, multiply the standard capacity by the appropriate correction factor(s).

EXAMPLE: Dryer Model: AEHD-500
Standard Capacity: 500 scfm
Actual Operating Conditions: 80°F ambient temperature: C1 = 1.15
90 psig system pressure: C2 = 0.91

Adjusted Capacity = 500 scfm x 1.15 x 0.91 = **523 scfm**

To Select the Dryer Model for Actual Conditions

Adjusted Capacity = scfm/C1/C2

To choose a dryer based on a given flow at non-standard operating conditions, divide the given flow by the appropriate correction factor(s).

EXAMPLE: Given Flow: 500 scfm
Actual Operating Conditions: 80°F ambient temperature: C1 = 1.15
130 psig system pressure: C2 = 1.27
Adjusted Capacity = 500 scfm / 1.15 / 1.27 = **342 scfm**

Selected Dryer Model: **AEHD-350**

The Compressed Air and Gas Institute (CAGI) has developed standards to protect users of compressed air & gas equipment. ADF 200 is the current standard for desiccant compressed air dryers. ADF 200 specifies the dryers performance to be rated at -40°F pressure dew point, 100°F inlet temperature,

100°F ambient temperature, and 100 psig system pressure. To adjust the dryer capacity from these "CAGI conditions" to your specific application, please use the correction factors below for differing inlet air temperatures (C1) and system pressures (C2).

The externally heated desiccant dryers with 7% dry purge will produce -40°F pressure dewpoint outlet under the following conditions:

1. For 100 psig or higher compressed air and 100°F or lower inlet temperature when used for single duty shift, 8 hours per day, and left on-stream to regenerate during the evening shifts and weekend.
2. For 100 psig or higher compressed air and 100°F or lower inlet temperature when used with an optional air ejector and venturi for continuous duty.
3. For 100 psig or higher compressed air and 65°F or lower inlet temperature for continuous duty.

Capacity correction factors for inlet air temperature (C1)

Ambient Temperature (°F)	70	80	90	100	105	110
Correction Factor	1.2	1.15	1.1	1	0.9	0.8

Capacity correction factors for system air pressure (C2)

System Pressure (psig)	60	70	80	90	100	110	120	130	140	150
Correction Factor	0.65	0.73	0.82	0.91	1	1.09	1.18	1.27	1.35	1.44